

FILE: J:\CUSTDWG\CATRL\CD-01203

INDUCTANCE

4.2 mH

LOSSES

41 Watts

WEIGHT

18 Lbs

NO.

CHANGE DESCRIPTION

BY

DATE

C'K'D

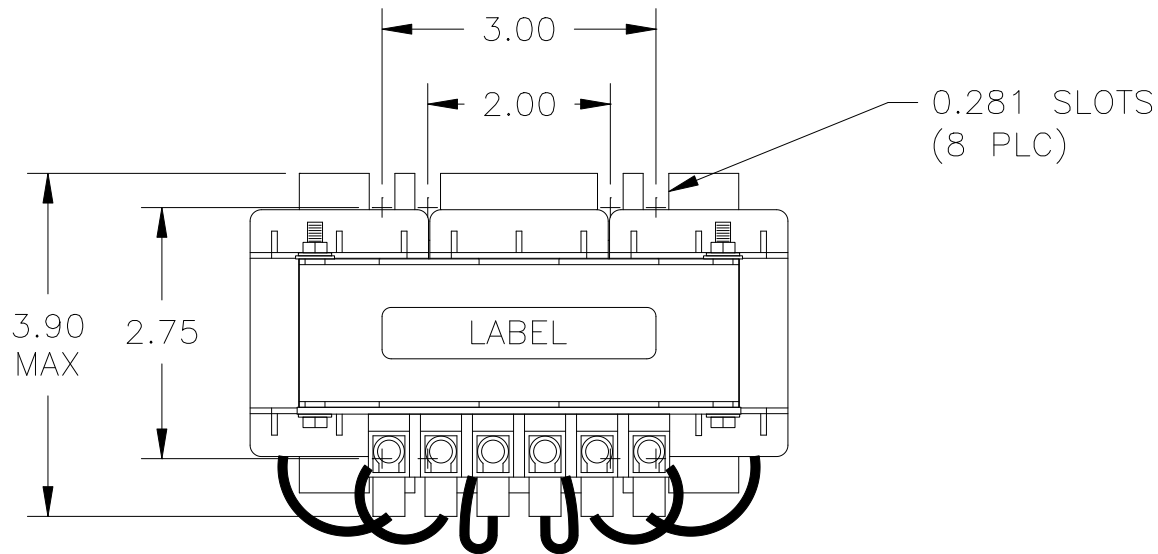

WIRE RANGE: 22-5 AWG

CAUTION- TERMINAL SCREW TIGHTENING TORQUE: 16 in-lb MAX.

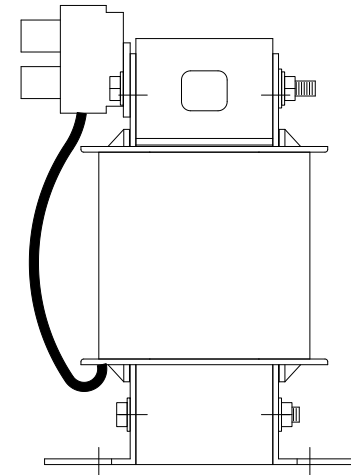
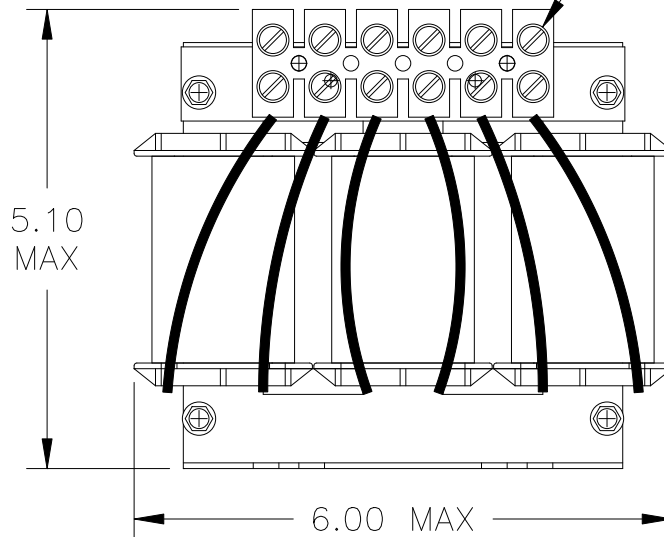

UNLESS OTHERWISE SPECIFIED, DIMENSIONS ARE IN INCHES [mm] AND TOLERANCES ARE:

DECI.                      FRAC.

ANGLES                    DRILLED HOLES

PART NAME: 3-PHASE REACTOR

DESCRIPTION: OUTLINE DIMENSION

FINISH:

MTE CORPORATION  
MENOMONEE FALLS, WISCONSIN

RL-01203

REV.  
09

SCALE	NTS	DATE	06/18/96	C'K'D
REF.		DR. BY	CEL	APP'D